

J. T. KREBS.

LEATHER SPLITTING MACHINE.

No. 306,760.

Patented Oct. 21, 1884.

Fig 1.

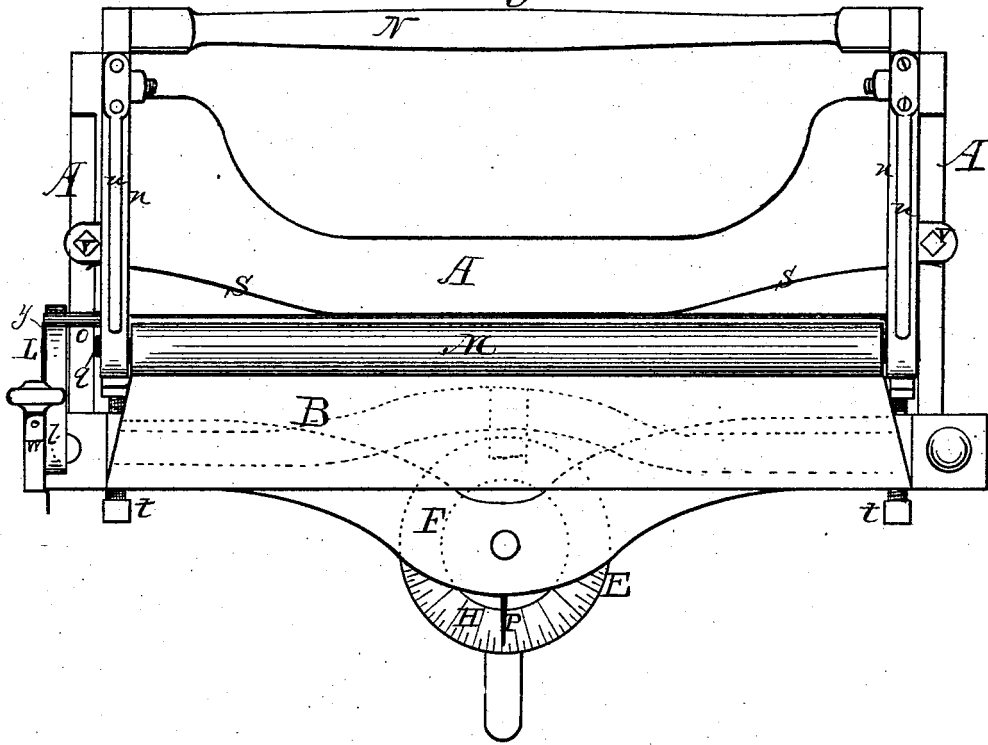
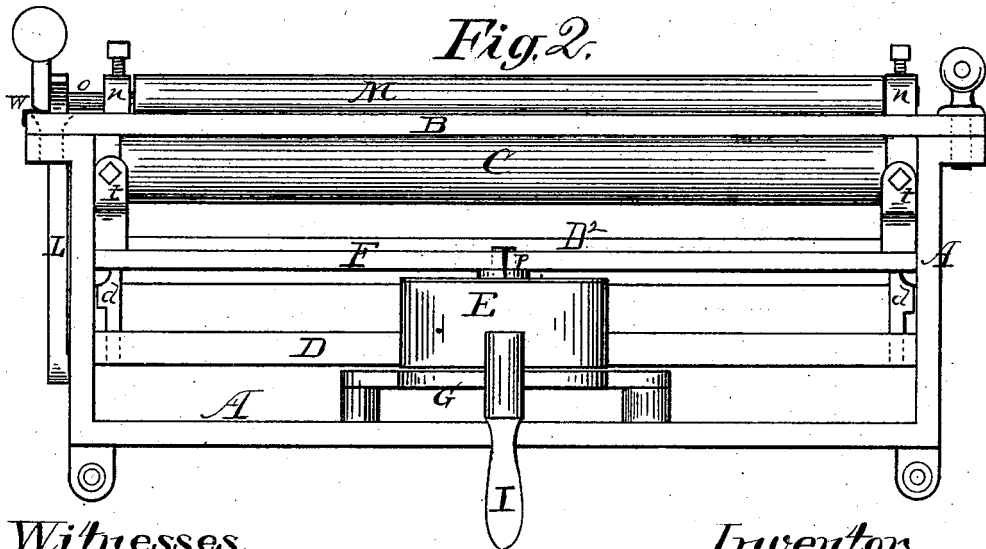

Fig 2.



Witnesses.  
*W. A. King*  
*Geo. B. Tibbitts*

Inventor,  
*John T Krebs*  
 Per *Geo. W. Tibbitts*  
 Attorney

J. T. KREBS.

LEATHER SPLITTING MACHINE.

No. 306,760.

Patented Oct. 21, 1884.

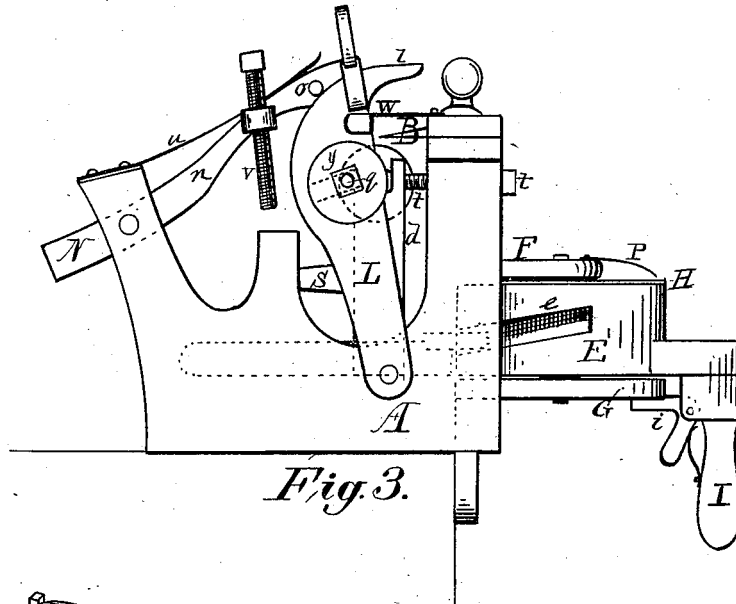

Fig. 3.

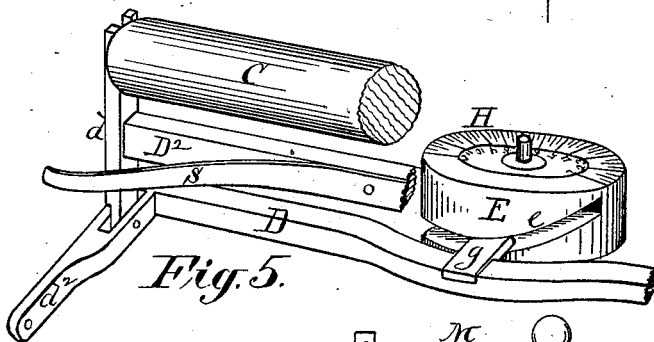

Fig. 5.

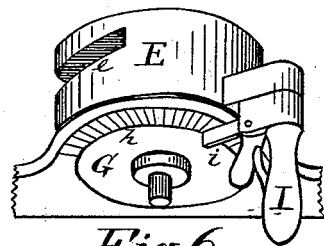

Fig. 6.

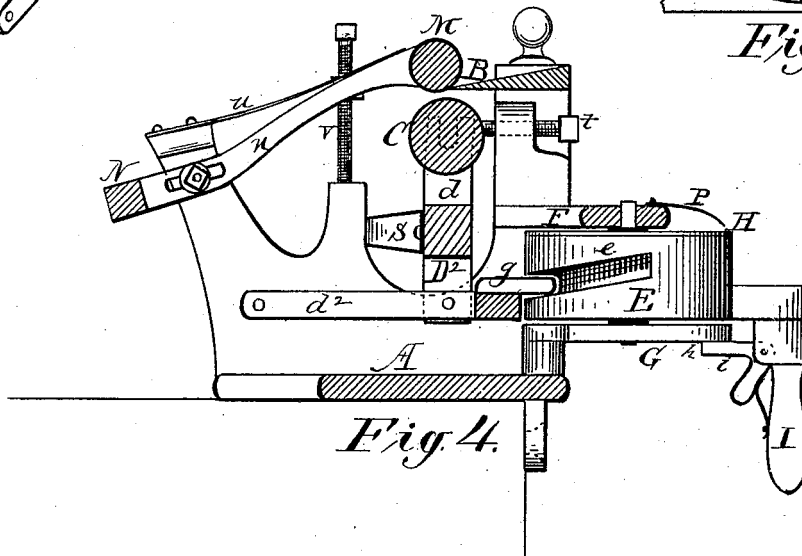

Fig. 4.

Witnesses.  
*W. A. King*  
*Geo. B. Tibbitts.*

Inventor,  
*John T. Krebs,*  
 per *Geo. W. Tibbitts*  
 Attorney.

# UNITED STATES PATENT OFFICE.

JOHN THEODORE KREBS, OF CLEVELAND, OHIO, ASSIGNOR TO WILLIAM A. KING, OF SAME PLACE.

## LEATHER-SPLITTING MACHINE.

SPECIFICATION forming part of Letters Patent No. 306,760, dated October 21, 1884.

Application filed February 25, 1884. (No model.)

*To all whom it may concern:*

Be it known that I, JOHN T. KREBS, of Cleveland, in the county of Cuyahoga and State of Ohio, have invented certain new and useful Improvements in Leather-Splitting Machines, of which the following is a specification.

This invention relates to machines for splitting leather; and it consists in a new and novel construction and arrangement of mechanism in which there is a knife, combined with adjustable rollers, and a roller-setting mechanism provided with a graduated scale, whereby the operator readily adjusts the machine to any required degree, enabling him to maintain a uniformity in thickness in splitting leather, the object of which is to provide a machine which requires no calculating, testing, or trying to adjust, resulting in a saving of time and labor.

In the accompanying drawings, Figure 1 is a top or plan view, and Fig. 2 is a side elevation, and Fig. 3 an end elevation, of my new leather-splitting machine. Fig. 4 is a cross-section showing the roller-setting device. Fig. 5 is a perspective view partly in section, and broken to show the connection of the roller-supporting frame with the setting device. Fig. 6 is a detached under side view of the said setting device.

A in the several figures is a frame which supports all the working parts of the machine, consisting of a bed-plate having uprights at each end, in which are the bearings for the operating mechanisms.

B is a knife or cutting-blade, which is of the usual form. It is secured to the top of the corner-posts of the frame with screws, one of which is a thumb-screw, designed to enable the knife to be readily removed for sharpening or adjustment.

C is a roller journaled in the upper ends of two upright arms, *d d*, pivoted at their lower ends in the corners of a frame, D, whose end bars, *d'*, are also pivoted to the end supports of the frame A. This frame supports the roller C beneath the knife B, and is held adjustable in relation therewith by the setting mechanism before mentioned, which consists of a wheel or roller, E, having a cam-groove, *e*, in its periphery, and vertically journaled in a bar, F,

in the frame A, and a bracket, G, attached to and extending outward from the bed-plate. An arm or lip, *g*, on the side of the frame D, plays in the aforesaid cam-groove *e*. On the upper side of the wheel E is made a circular graduated scale, H, representing the various thicknesses or degrees of thickness which are required for splitting or shaving leather. The under side of the bracket G has a curved rack, *h*, corresponding in number of teeth with the above scale. The wheel E is provided with a depending handle, I, for rotating it, and which is provided with a spring-latch, *i*, engaging with the said rack *h*, designed to hold the wheel in position when adjusted at any given point. A pointer, *p*, is attached to the bar F, which points off and indicates the degrees on the scale H. A spring, S, is attached to the longitudinal bar D<sup>2</sup> of the frame supporting the roller C, whose ends bear against the middle posts of the frame A. This is provided to allow the roller to be tilted back, but not to fall, in inserting the leather between the said roller and the knife. Adjustable screw-stops *t t* are placed in the corner-posts of the frame A, against which the arms *d d* rest, and limit the movement of said roller under the knife. A second roller, M, is provided, which lies above the knife and roller C. This roller M is journaled in the ends of arms *n n* of a tilting frame, N, adjustably pivoted to the rear corner-posts of the frame A. Springs *u u* are secured to the tops of said posts, whose free ends bear upon the arms *n n*. Said arms are also provided with adjustable screw-stops *v v*, which rest on the tops of the intermediate posts at the ends of frame A.

To one end of the frame A is pivoted a lever, L, having a curved top arm, *l*, upon which a pin, *o*, on the arm *n* of tilting frame N, slides. This is designed for lifting the roller M away from the knife, when desired. A stop, W, pivoted at one of its ends to top of post, may be turned around, as seen in Fig. 3, to hold the lever L and roller M away from knife. The lever has a slot, through which a pin, *q*, attached to upright *d*, extends, provided with embracing-plates *y* on each side of the lever. This allows the lever to be tilted the length of the slot without disturbing the roller C. Roller C may be tilted, however, by

carrying the lever farther over. This tilting lever is designed for use in tilting the rollers over, to allow room for first inserting the leather under the knife.

5 From the foregoing the operation of this machine will be apparent. The roller C, which determines the thickness in splitting the leather, is simply and readily adjusted, thereby greatly facilitating and insuring perfect uniformity of work.

10 Having described my invention, I claim—

1. In a leather-splitting machine, the combination, with the splitting-knife, of a mechanism, substantially as described, constructed and arranged to hold the roller C adjustably in its relation to the knife, and a graduated-scale mechanism constructed and arranged for setting and holding the said roller-holding mechanism, substantially as described.

20 2. The combination, in a leather-splitting machine, of a graduated-scale mechanism, con-

sisting of the cam-grooved wheel E, having graduate H, and provided with handle I, having spring-latch *i*, engaging with rack *h* on the bracket G, operating to set and hold the roller-holding mechanism, substantially as specified. 25

3. The combination, in a leather-splitting machine, of the second roller, M, journaled in arms *n n* of frame N, adjustably hung to posts of the frame A, and provided with bearing-springs *u u* and screw-stops *v v*, substantially as specified. 30

4. The lever L, pivoted to the end support of the frame A, and provided with curved arm *l*, and having slot *y* and the pivoted stop W, in combination with the two roller mechanisms for operating said mechanisms, substantially as and for the purpose specified. 35

JOHN THEODORE KREBS.

Witnesses:  
E. W. LAIRD,  
GEO. W. TIBBITTS.